



# BCS

## High Resolution Digital Crane Scale



## User Instructions

Brecknell is part of Avery Weigh-Tronix. Avery Weigh-Tronix is a trademark of the Illinois Tool Works group of companies whose ultimate parent company is Illinois Tool Works Inc ("Illinois Tool Works"). Copyright © 2014 Illinois Tool Works. All rights reserved.

No part of this publication may be reproduced by making a facsimile copy, by the making of a copy in three dimensions of a two-dimensional work and the making of a copy in two dimensions of a three-dimensional work, stored in any medium by electronic means, or transmitted in any form or by any means, including electronic, mechanical, broadcasting, recording or otherwise without the prior written consent of the copyright owner, under license, or as permitted by law.

This publication was correct at the time of going to print, however Avery Weigh-Tronix reserves the right to alter without notice the specification, design, price or conditions of supply of any product or service at any time.

# Table of Contents

<b>Chapter 1 General Information and Warnings</b> .....	5
About this Manual .....	5
Text Conventions .....	5
Special Messages .....	5
Safe Handling of Equipment with Batteries .....	6
Safety Guide .....	6
Routine Maintenance .....	6
Training .....	7
Sharp Objects .....	7
FCC and EMC Declarations of Compliance .....	7
Declaration of Conformity .....	8
<b>Chapter 2 Introduction</b> .....	10
Features .....	10
Specifications .....	10
Capacity .....	11
Dimensions and Weight .....	11
Display and Keys .....	12
Faceplate .....	12
Scale Keys .....	12
Remote Keys .....	13
Display Annunciators .....	14
Displayed Messages .....	14
<b>Chapter 3 Operation</b> .....	15
Power On/Off .....	15
Zero .....	15
Tare In/Out .....	15
Lock / Unlock .....	16
Accumulate .....	16
View .....	16
Delete Last Weight .....	16
Clear All Weight .....	17
Unit Switching .....	17
<b>Chapter 4 User Menu</b> .....	18
Access User Setup Menu .....	18
Parameters .....	18
Auto-Off Timing .....	18
Display Brightness .....	18
Idle Mode Timing .....	19
<b>Chapter 5 Loading Procedures</b> .....	20
Correct Loading .....	20
Incorrect Loading .....	21
<b>Chapter 6 Maintenance and Troubleshooting</b> .....	23
Battery Maintenance .....	23
Troubleshooting .....	23



# 1 General Information and Warnings

## 1.1 About this Manual

---

This manual is divided into chapters by the chapter number and the large text at the top of a page. Subsections are labeled as shown by the 1 and 1.1 headings shown above. The names of the chapter and the next subsection level appear at the top of alternating pages of the manual to remind you of where you are in the manual. The manual name and page numbers appear at the bottom of the pages.

### 1.1.1 Text Conventions

---

Key names are shown in **bold** and reflect the case of the key being described. This applies to hard keys and onscreen or soft keys.

Displayed messages appear in ***bold italic*** type and reflect the case of the displayed message.

### 1.1.2 Special Messages

---

Examples of special messages you will see in this manual are defined below. The signal words have specific meanings to alert you to additional information or the relative level of hazard.



---

**CAUTION!**

*This is a Caution symbol.*

***Cautions give information about procedures that, if not observed, could result in damage to equipment or corruption to and loss of data.***

---



---

**NOTE:** *This is a Note symbol. Notes give additional and important information, hints and tips that help you to use your product.*

---

## 1.2 Safe Handling of Equipment with Batteries

---



**CAUTION:** *Danger of explosion if battery is incorrectly replaced. Replace only with the same or equivalent type recommended by the manufacturer. Dispose of used batteries according to the manufacturer's instructions.*

---

**ATTENTION:** *Il y a danger d'explosion s'il y a remplacement incorrect de la batterie, remplacer uniquement avec une batterie du même type ou d'un type équivalent recommandé par le constructeur. Mettre au rebut les batteries usagées conformément aux instructions du fabricant.*

---

## 1.3 Safety Guide

---

For the best performance and precise measurement

- 1 Do NOT overload the scale. This will damage the loadcell and void the warranty.
- 1 Do NOT leave a load on the scale when not in use. This will decrease the scale's accuracy and shorten the loadcell life.
- 1 Inspect the shackle and hook before using. Check clips, pins and screws regularly.
- 1 Check the battery frequently. When the scale display flashes, charge the battery with its dedicated charger.
- 1 Rotate the load rather than the scale if binding occurs.
- 1 DO NOT use the scale during thunder storms
- 1 Hang scale while in storage in dry and well-ventilated room. Do NOT place the scale directly on the ground.
- 1 Do NOT attempt to repair the scale yourself. Contact your local representative.

## 1.4 Routine Maintenance

---



**IMPORTANT:** *This equipment must be routinely checked for proper operation and calibration. Application and usage will determine the frequency of calibration required for safe operation.*

---

## **1.5 Training**

---

Do not attempt to operate or complete any procedure on a machine unless you have received the appropriate training.

To avoid the risk of RSI (Repetitive Strain Injury), place the machine on a surface which is ergonomically satisfactory to the user. Take frequent breaks during prolonged usage.

## **1.6 Sharp Objects**

---

Do not use sharp objects such as screwdrivers or long fingernails to operate the keys.

## **1.7 FCC and EMC Declarations of Compliance**



---

This is a Class B device.







<b>UK CA</b>	<b>UK Declaration of Conformity</b>
<b>Model / Type: BCS</b>	
Serial Number: <b>101400001 Onwards</b>	
Name and address of the manufacturer: <b>Avery Weigh-Tronix<sup>1</sup> Foundry Lane Smethwick West Midlands S66 2LP ENGLAND</b>	
This declaration of conformity is issued under the sole responsibility of the manufacturer.	
Object of the declaration: Brecknell <sup>®</sup> BCS-4000 Brecknell <sup>®</sup> BCS-3000 Brecknell <sup>®</sup> BCS-6000	
	
The machinery fulfills all the relevant provisions of the Machinery Directive <b>2006/42/EC<sup>3</sup></b>	
The object of the declaration described above is in conformity with the relevant statutory requirements applicable to the specific product:	
Statutory Requirements	UK standards or other technical specifications
Electromagnetic Compatibility Regulations 2016	<b>BS EN61000-6-1:2007 BS EN61000-6-3:2007 +A1:2011 +AC:2012</b>
The Ecodesign for Energy-Related Products Regulations 2010	<b>UK Statutory Instrument 2010 No.2617</b>
Electrical Equipment (Safety) Regulations 2016	<b>BS EN62368-1:2014 +A11:2017</b>
The Restriction of the Use of Certain Hazardous Substances in Electrical and Electronic Equipment Regulations 2012 (as amended)	<b>BS EN 63000:2018</b>
Additional information:	
<b>Note 1:</b> ITW Ltd trading as Avery Weigh-Tronix Reg. Office: Saxon House, 2-4 Victoria Street, Windsor, SL4 1EN, England	
<b>Note 2:</b> Brecknell is part of Avery Weigh-Tronix	
<b>Note 3:</b> A copy of the Technical File for this equipment is available from M.S. Williams at the address above.	
Signed for and on behalf of: <b>Avery Weigh-Tronix</b> at <b>1000 Armstrong Drive, Fairmont, MN, 56031-1439, USA</b> on <b>2024-08-13</b>	
	
<b>A. Sukalski R&amp;D Director</b>	

76501-549UK Issue 3

## 2 Introduction

### 2.1 Features

---

This scale is a combination of sound and proven mechanical design, using the most advanced electronics and provides a superb feature set. It is versatile, reliable, accurate and easy to operate.

- 1 Superb Quality - Chinese GB/T11883-2002 national standards.
- 1 Exceptional Safety - The aluminum-cast case, secure hook and shackle, provide for safe installation and use.
- 1 Reliability - Cutting-edge technology with quality integrated circuitry insure high performance and long time stability.
- 1 Easy to Use - Operation via local keypad or infrared remote control.
- 1 Complete Functionality - Resolution switch, unit conversion, auto power-off, battery inspection, etc.

### 2.2 Specifications

---

<b>Accuracy Class</b>	Chinese GB/T 11883-2002 Class III
<b>Tare Range</b>	100% F.S.
<b>Zero Range</b>	4% F.S.
<b>Stable Time</b>	≤10sec
<b>Overload</b>	100% F.S. + 9e
<b>Safety Load</b>	150% F.S.
<b>Ultimate Load</b>	400% F.S.
<b>Battery</b>	6V/4.0Ah lead acid rechargeable battery
<b>Charger</b>	100~250VAC 50/60Hz input 7.2VDC/1000mA output
<b>Display</b>	35mm (1.4inch) LED module
<b>Operating Temp.</b>	-10°C ~ +40°C
<b>Operating Humidity</b>	20°C ≤90%

## 2.3 Capacity

Model	Maximum Capacity	Minimum Capacity	Resolution	Division
BCS-1000	1,000kg (2,000 lb)	10kg (20 lb)	0.5kg (1 lb)	2,000
BCS-3000	3,000kg (6,000 lb)	20kg (40 lb)	1kg (2 lb)	3,000
BCS-5000	5,000kg (10,000 lb)	40kg (80 lb)	2kg (5 lb)	2,500

## 2.4 Dimensions and Weight

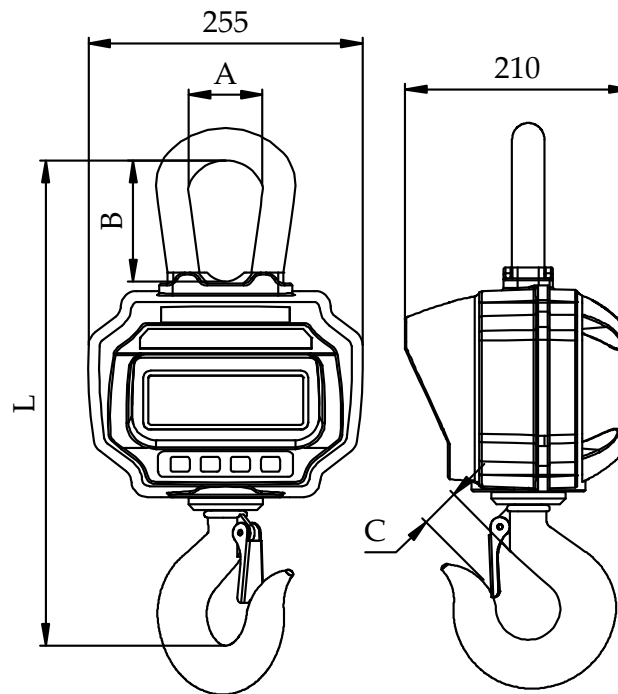

Model	A	B	C	L	Net Weight
BCS-1000	68mm (2.67")	112mm (4.41")	40mm (1.60")	420mm (16.54")	11.0kg (24.25 lb)
BCS-3000	68mm (2.67")	112mm (4.41")	40mm (1.60")	420mm (16.54")	11.0kg (24.25 lb)
BCS-5000	68mm (2.67")	112mm (4.41")	45mm (1.77")	450mm (17.71")	12.5kg (27.56 lb)

## 2.5 Display and Keys



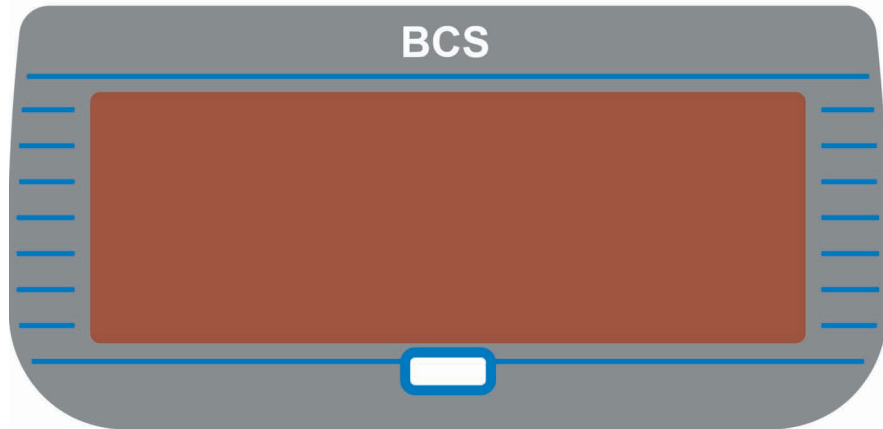

---

### 2.5.1 Faceplate



### 2.5.2 Scale Keys



Keys	Key Name	Function
	On/Off	Press 1s to power on/off scale Return to weighing mode
	Zero	Manual Zero Increase flashing digit
	Tare	Tare in/out Right scroll flashing digit
	Hold	Lock/unlock reading Confirm

## 2.5.3 Remote Keys

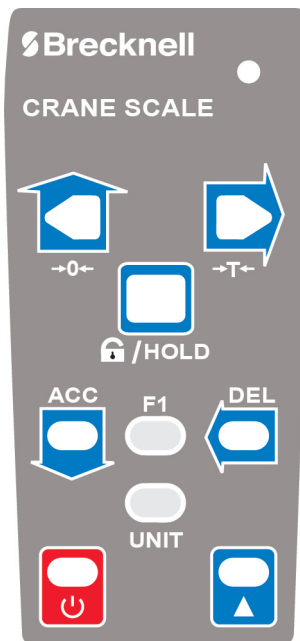

Keys	Key Name	Function
	Zero	Same as
	Tare	Same as
	Hold	Same as
	Accumulate	Accumulate weight Decrease flashing digit
	Delete	Delete last weight Clear all weight Left scroll flashing digit
	F1	View Input decimal point
	Unit	Unit switching
	Off	Press 1s to power off Return to weighing mode
	2nd	2nd function.

## 2.5.4 Display Annunciators

---

Annunciator	Name	Note
STB.	Stable	lit when weight is stable
ZERO	Zero	lit when weight is at zero
TARE	Tared	lit when scale is tared
HOLD	Hold	lit when scale weight is locked
lb	lb	lit when unit is lb
kg	kg	lit when unit is kg

## 2.5.5 Displayed Messages

---

Message	Description	Note
----	detect weight	
?	in Idle Mode	
<i>Setup</i>	SETUP	User Setup Menu
<i>Bat??</i>	BATtery	battery life percentage
<i>P0000</i>	Password	in Password Mode
end	END	save and exit
off	OFF	power off
over	OVERload	overloading
2nd	2ND	2nd function
err	ERRor	invalid operation
acc	ACCumulate	accumulate weight
del	DELeTe	delete last weight
Clr	CLear	delete all weight

## 3 Operation

### 3.1 Power On/Off

---

1. Press  for 1 second to power-on scale.



Scale performs initialization and power-on test, \*\*\*\*\* shows twice. Next the display shows the capacity, battery life percentage, weight detection, and then auto zero.



---

*NOTE: For information about Auto-Zero, refer to Scale Configuration in Technical Manual.*



---

2. Press  or  for 1 second to power-off scale.

Battery life percentage **bat90** is displayed, off message **|off|** is displayed, and then the power turns off.

### 3.2 Zero

---

- Press  or  to zero. The ZERO light will turn on.

If load is in motion, tared, or out of Manual-Zero Range, **|err|** is displayed.



---

*NOTE: For information about Manual-Zero Range, refer to Scale Configuration in Technical Manual.*

---

### 3.3 Tare In/Out

---

1. In gross mode, press  or  to tare in. TARE light will turn on.

If load is in motion, negative value, or out of Tare Range; **|err|** is displayed.



---





*NOTE: Tare will reduce the apparent overload range of scale. For example, if a 5000\*2kg scale has a 1000kg container as its tare, the scale will overload at a new weight of 4018kg (5000 - 1000 + additional 9 divisions).*

---

2. In net mode, press  or  to tare out. TARE light will turn off.

### 3.4 Lock / Unlock

---

1. Press  or  to lock screen. HOLD light will turn on.
2. Press  or  to unlock screen. HOLD light will turn off.

### 3.5 Accumulate

---





Press  to accumulate current weight.

**|acc|** is displayed, indicating weight is accumulated. Scale uses displayed weight, so gross or net weight is added into the same accumulator.

If load is in motion, or negative, or does not return to zero before, **|err|** is displayed.

### 3.6 View

---

1. Press  to enter View mode.  
Display flashes accumulated weight.
2. Press  or  to view high 5-digit or low 5-digit.
3. Press  or  to exit View mode.

### 3.7 Delete Last Weight

---

Press  to delete last accumulated weight.

**|del|** is displayed, indicating last accumulated weight is deleted. The Delete function will only delete the last weight.

If last accumulated weight has been deleted, **|err|** is displayed.



## 3.8 Clear All Weight

---

Press  first and then press  to clear all accumulated weight.

|clr| is displayed, indicating all weight is cleared.

## 3.9 Unit Switching

---

Press  to switch unit in between kg, lb, and User Unit.

When unit is kg, kg LED light on. When unit is lb, lb LED light on. When unit is User Unit, kg and lb all lights are off.



---

*NOTE: For more information about User Unit, refer to Scale Configuration in Technical Manual.*

---

# 4 User Menu

## 4.1 Access User Setup Menu

---





Press  first and then press  or  to enter User Setup menu. **Setup** is displayed.

## 4.2 Parameters

---

### 4.2.1 Auto-Off Timing

---

1. Press  or  to enter Auto-Off Timing. **off??** is displayed.
2. Press  or  and  to change timing value.

Auto-Off Timing can be set to: 0(disabled), 5(5min), 10(10min), 15(15min), 30(30min), 60(60min). It is disabled by default.







---

*NOTE: Auto-Off function maximizes scale's battery life. Auto-Off starts countdown timer when there's no action or load is stable. Any key pressing or motion in load restarts countdown timer.*

---

### 4.2.2 Display Brightness

---

1. Press  or  to enter Display Brightness. **br||?** is displayed.
2. Press  or  and  to change brightness value.

Display Brightness can be set to: 1(dim), 2(normal), 3(bright).

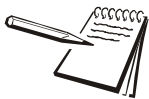





---

*NOTE: Dim LED brightness saves battery power dramatically.*

---

### 4.2.3 Idle Mode Timing

1. Press  or  to enter Idle Mode Timing. *idl??* is displayed.
2. Press  or  and  to change timing value.

Idle Mode Timing can be set to: 0(disabled), 5(5sec), 10(10sec), 15(15sec), 30(30sec), 60 (60sec). It is 30sec by default.

To maximize battery life, scale automatically enters Idle Mode, when there's no action or the load is stable. In Idle Mode, scale works in low-power consumption status. Any key pressing or motion in load wakes up scale from Idle Mode.

3. Press  or  to exit User Setup.

## 5 Loading Procedures

The following drawings illustrate how to load and how not to load the crane scale.

### 5.1 Correct Loading

---

Use hardware that creates single point attachments. Refer to Figure 5.1.

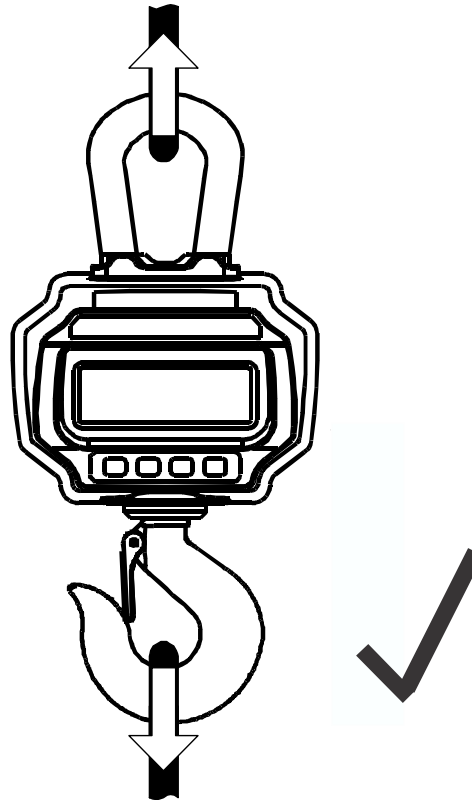

Figure 5.1 Correct Crane Scale Loading

## 5.2 Incorrect Loading

---

The following drawings demonstrate incorrect crane scale loading.

- 1 DO NOT attach oversized interface! Refer to Figure 5.2.

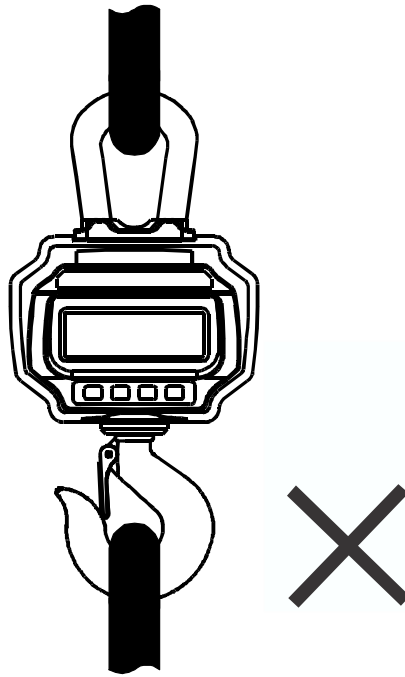

**Figure 5.2 Oversized Interface Attachment**

- 1 DO NOT push/pull on loaded scale or directly on hook! Refer to Figure 5.3

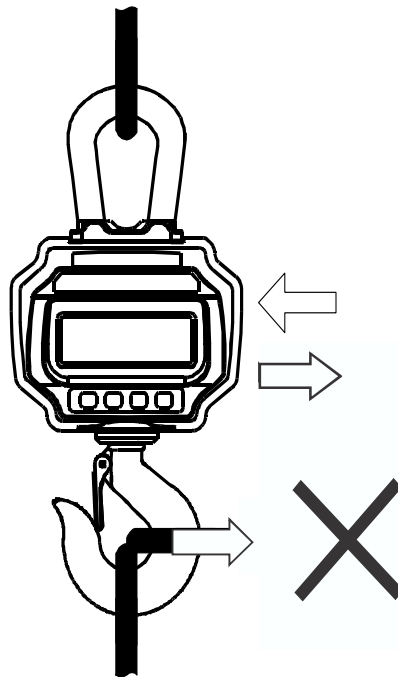

**Figure 5.3 Side Stress on Hook**

1 DO NOT use multiple attachments! Refer to [Figure 5.4](#).

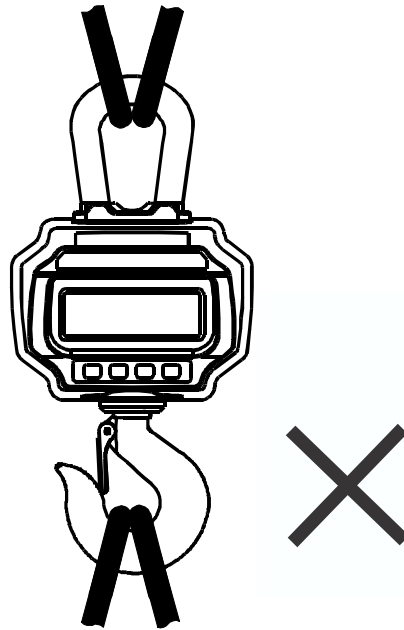

**Figure 5.4 Multiple Attachments**

# 6 Maintenance and Troubleshooting

## 6.1 Battery Maintenance

---

To maximize battery life, please note the following battery maintenance guide.

- 1 This scale is powered by a 6V4.0Ah rechargeable lead-acid battery.
- 1 The battery is permanently fixed inside battery housing.
- 1 Depending on LED brightness and idle mode settings, the battery works from 60 hours to 200 hours.
- 1 In order to conserve battery life, enable Auto-Off and Idle Mode, dim LED brightness.
- 1 Charging time for a completely discharged battery is approximately 12 hours.
- 1 To obtain maximum service life, battery should be stored between -20° (-4°F) and +50° (122°F). Stored batteries should be recharged every three months.
- 1 While charging, the red LED indicates charging in progress, while the green LED indicates fully charged.

## 6.2 Troubleshooting

---

Refer to the table below for possible symptoms and solutions. If problems still exist, please contact your local representative.

Symptom	Possible Cause	Suggested Solution
will not power-on after On/Off is pressed	discharged / defective battery	check battery and charge
	defective On/Off key	press harder and keep pressing 2s
	defective power cable	open front panel, check power cable
	defective mainboard	contact representative
display flashes	discharged battery	charge battery
no action taken after key pressed	defective key	contact representative
weight reading not stable	load in motion	keep load stable
	weak Anti-Motion	change Anti-Motion level
	damp loadcell or mainboard	dry loadcell or mainboard
	defective mainboard	contact representative
weight reading not zero when no load	discharged battery	charge battery
	loadcell stressed too long	hang scale in storage
	discharged battery	charge battery

<b>Symptom</b>	<b>Possible Cause</b>	<b>Suggested Solution</b>
large error in weight reading	scale not zeroed before applying load	manual Zero scale before loading
	wrong weigh unit	switch to correct unit
	scale requires calibration	calibrate scale
	defective loadcell or mainboard	contact representative
battery can not be recharged	defective charger board	contact representative
	defective battery	contact representative
short remote control distance	discharged / defective remote battery	replace remote control batteries







**Brecknell USA**

1000 Armstrong Dr.  
Fairmont MN 56031  
Tel:507-238-8702  
Fax:507-238-8271  
Email: [sales@brecknellscales.com](mailto:sales@brecknellscales.com)  
<http://www.brecknellscales.com>

**Brecknell UK**

Foundry Lane,  
Smethwick, West Midlands,  
England B66 2LP  
Tel:+44 (0) 8452 46 6717  
Fax:+44 (0) 8452 46 6718  
Email:  
[sales@brecknellscales.co.uk](mailto:sales@brecknellscales.co.uk)  
<http://www.brecknellscales.com>